

APPLICATION:

PRODUCT NAME:

STOP ANGLE 1/2 X 1/2 XH

JOB NAME:

SPECIAL CONFIGURATION
 CHECK BASE MODEL AND OPTIONS

QUANTITY:

ITEM NO.

MODEL:

1790-1

OPTIONS OR MODIFICATIONS:

OTHER _____

FEATURES

CONTROL VALVE

- * STEM - RIGHT HAND
- * SWIVELLING SEAT DISK
- * INTERNAL SPRING LOADED CHECK VALVE
- * HOT AND COLD INDEX BUTTONS
- * STAINLESS STEEL SEAT
- * STAINLESS STEEL SEAT SCREW
- * STAINLESS STEEL HANDLE SCREW

SYSTEM LIMITS

- * TEMP: 40°F MIN. TO 140°F MAX.
- * PRESSURE: 200 PSI MAX. STATIC

SHIPPING WEIGHT

- * 1.0 LB

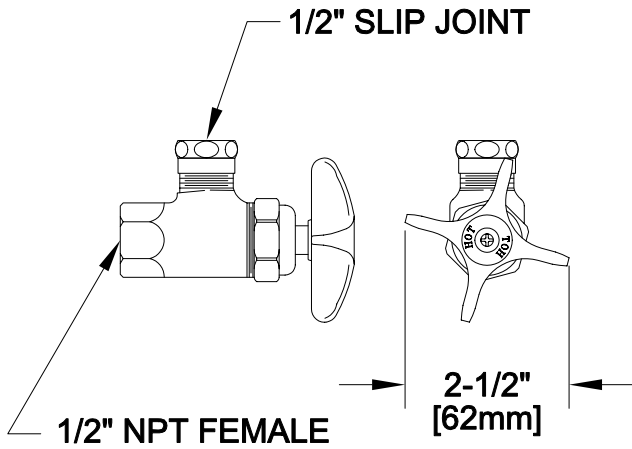

FISHER MANUFACTURING COMPANY

TOLL FREE: 800-421-6162 - FAX: 800-832-8238

information@fisher-mfg.com - www.fisher-mfg.com